

TABLE AXON

4

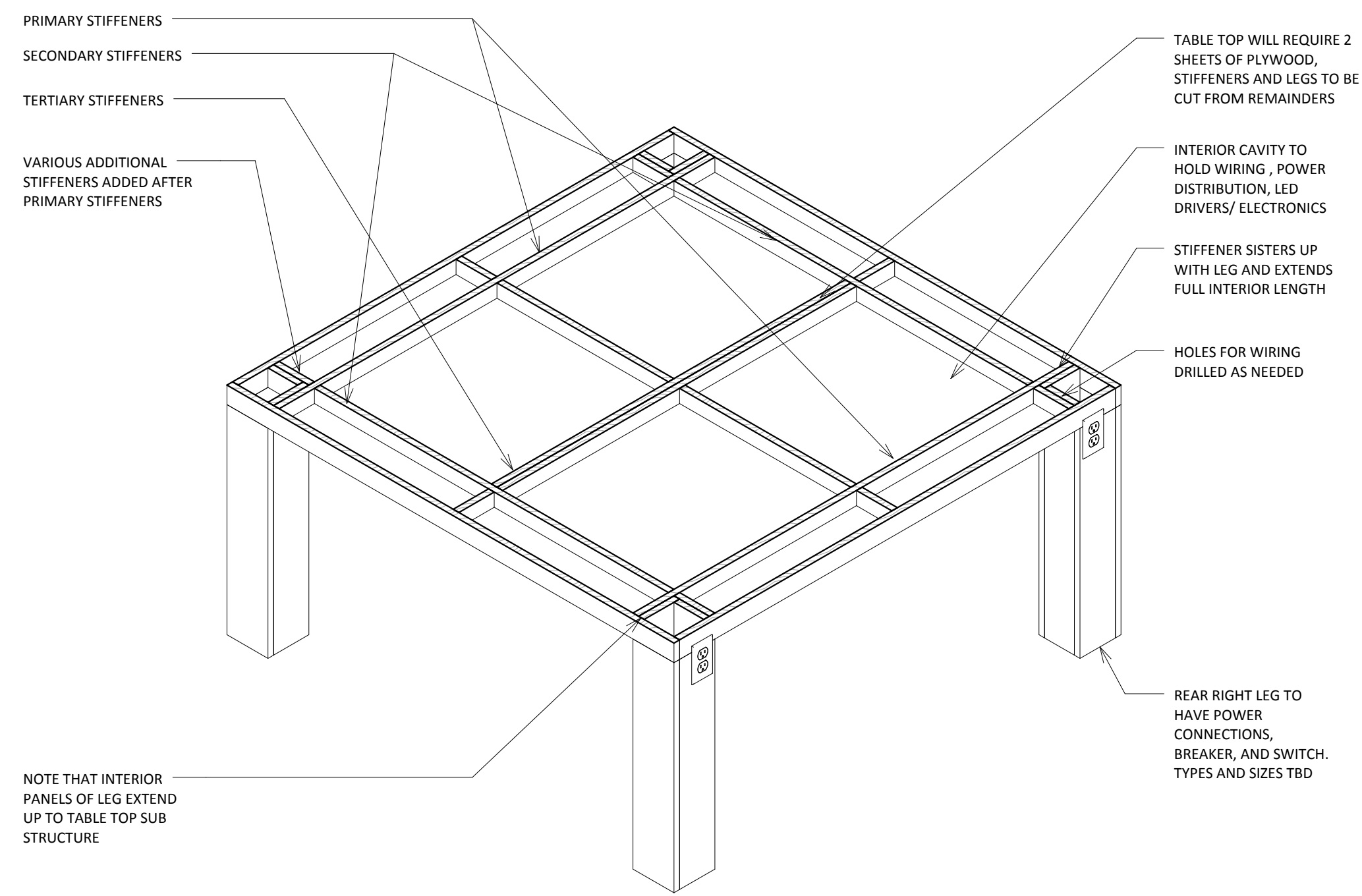

TABLE AXON INTERIOR

5

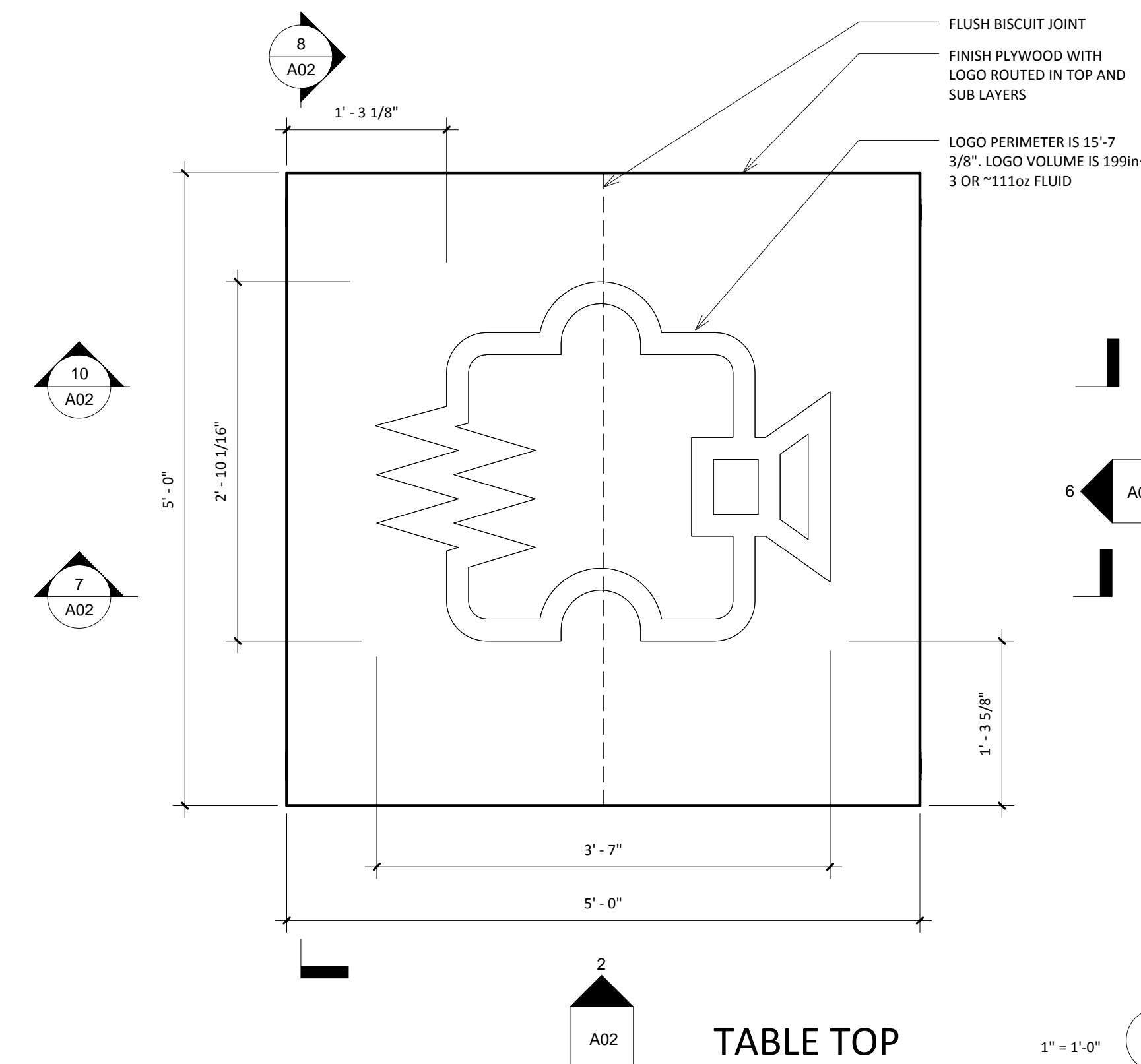

TABLE TOP

1

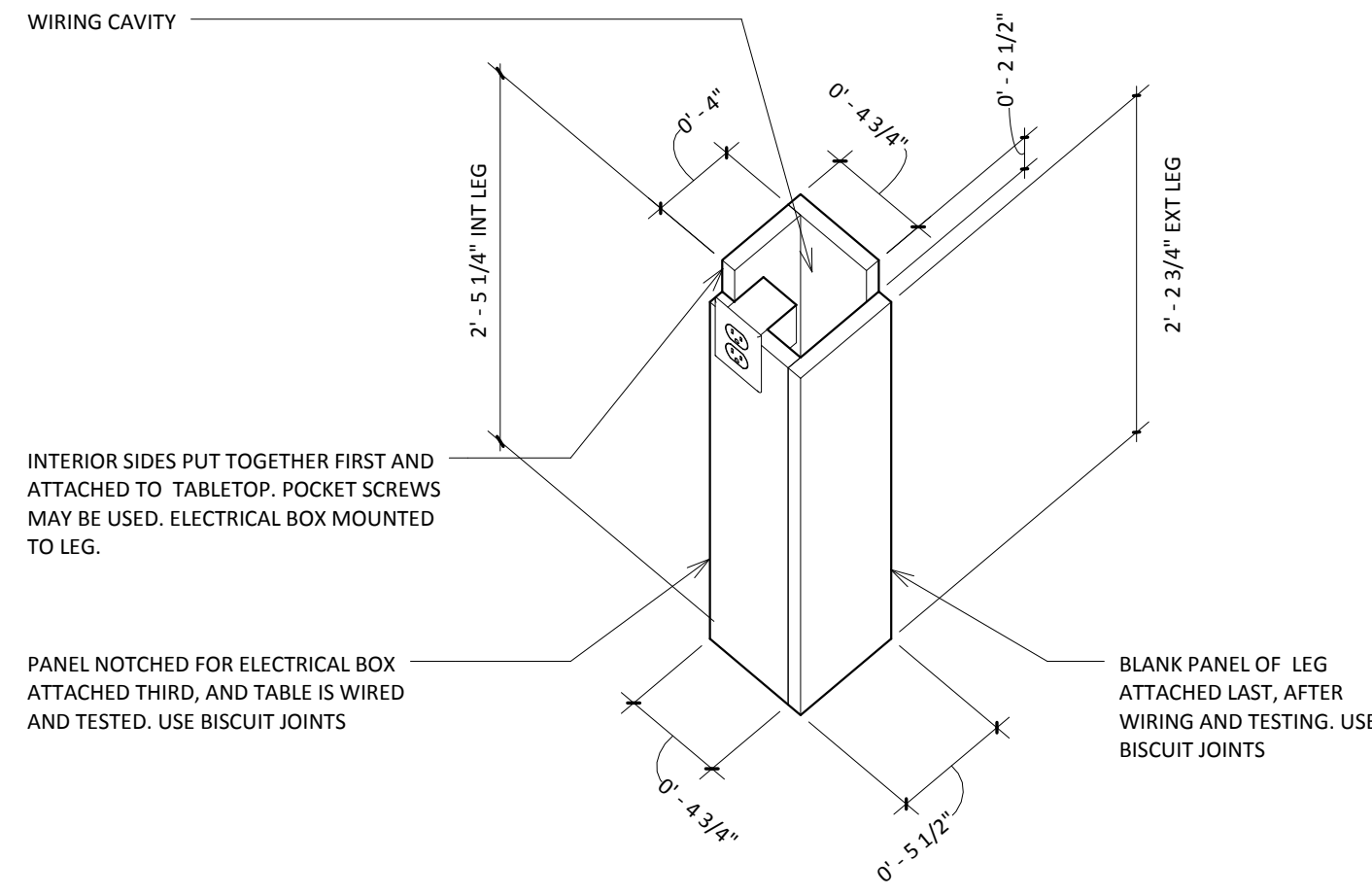
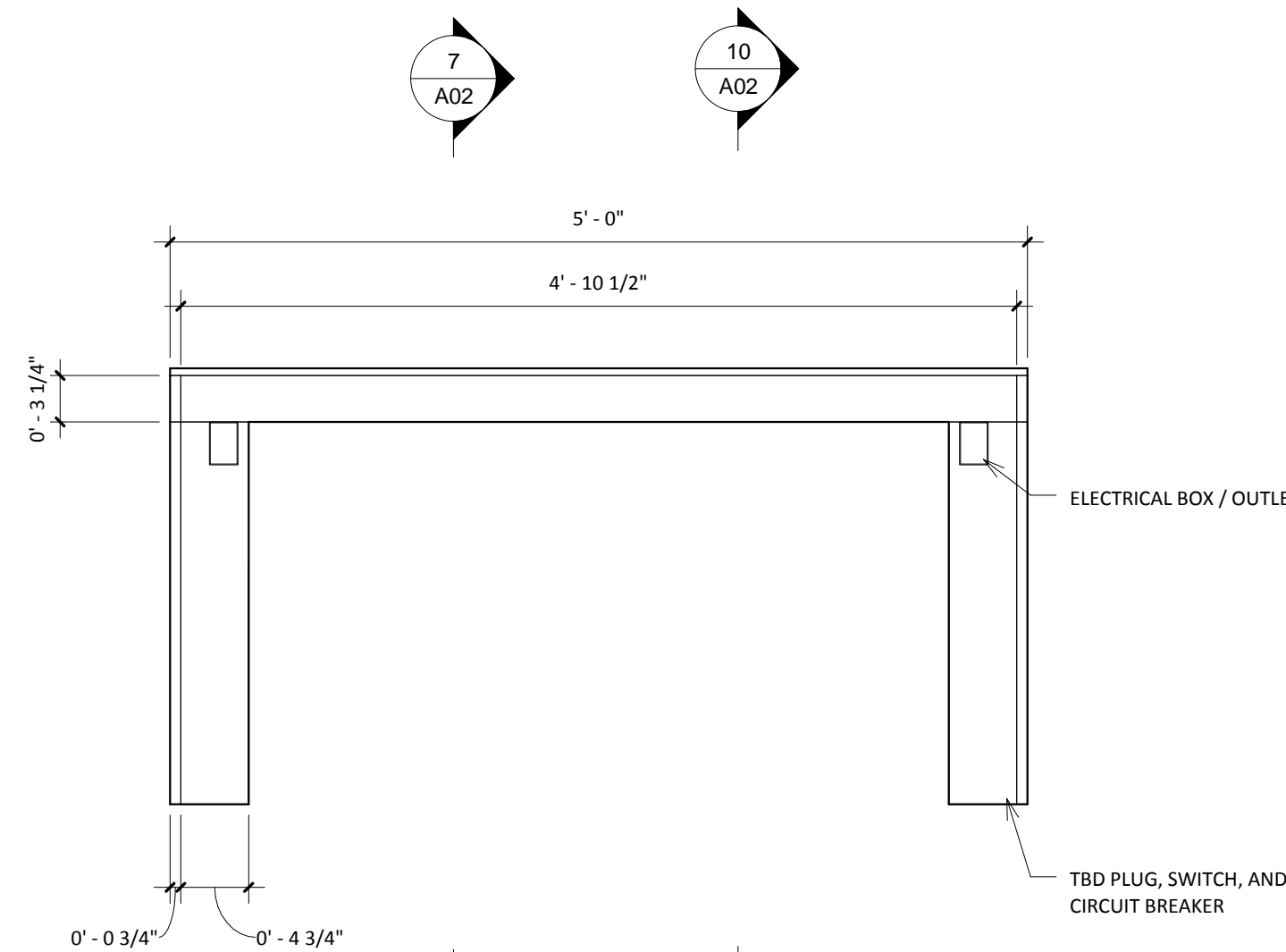

TABLE LEG DETAIL

3



RIGHT - LOGO TABLE

6

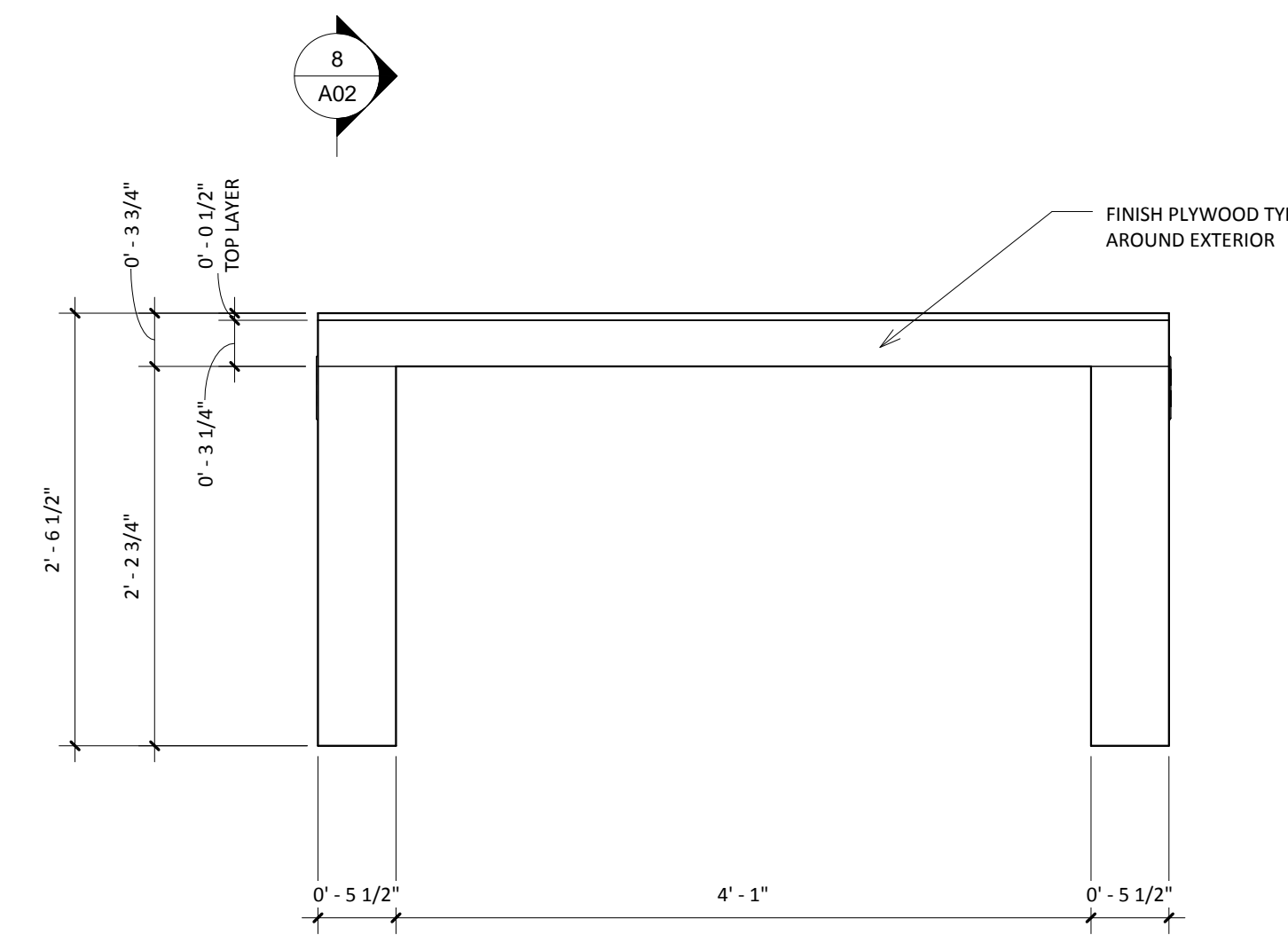

FRONT - LOGO TABLE

2

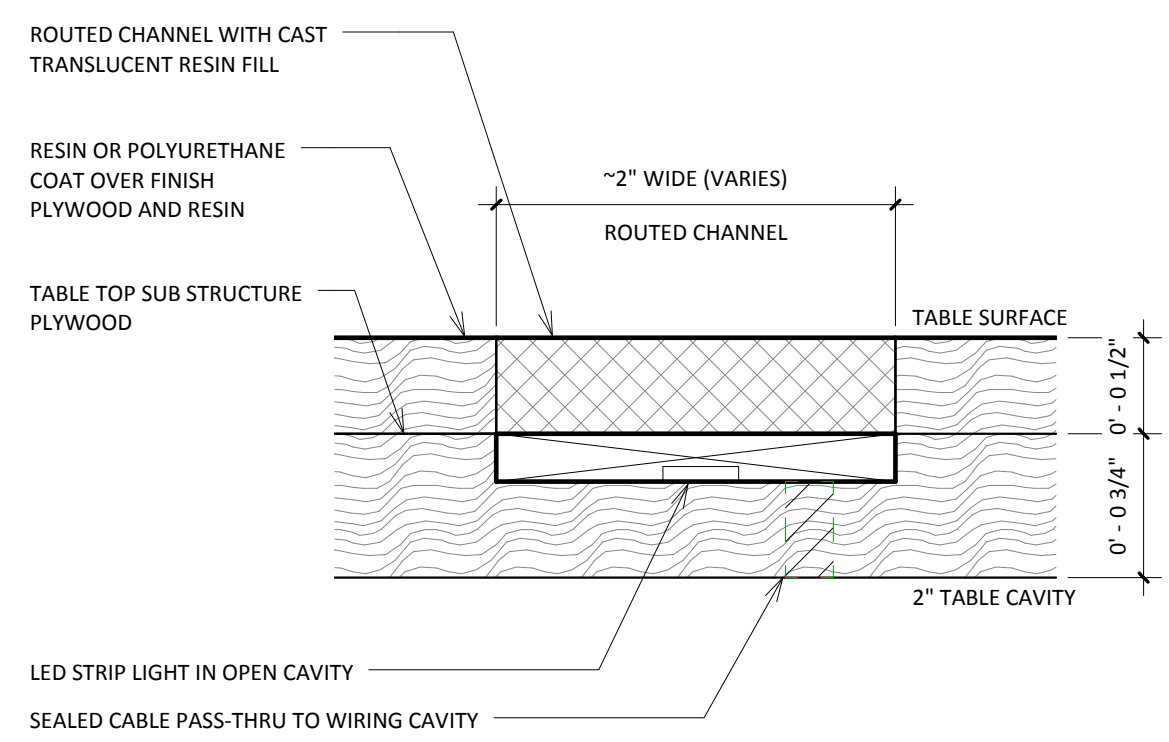

LOGO CHANNEL DETAIL

12" = 1'-0"

10

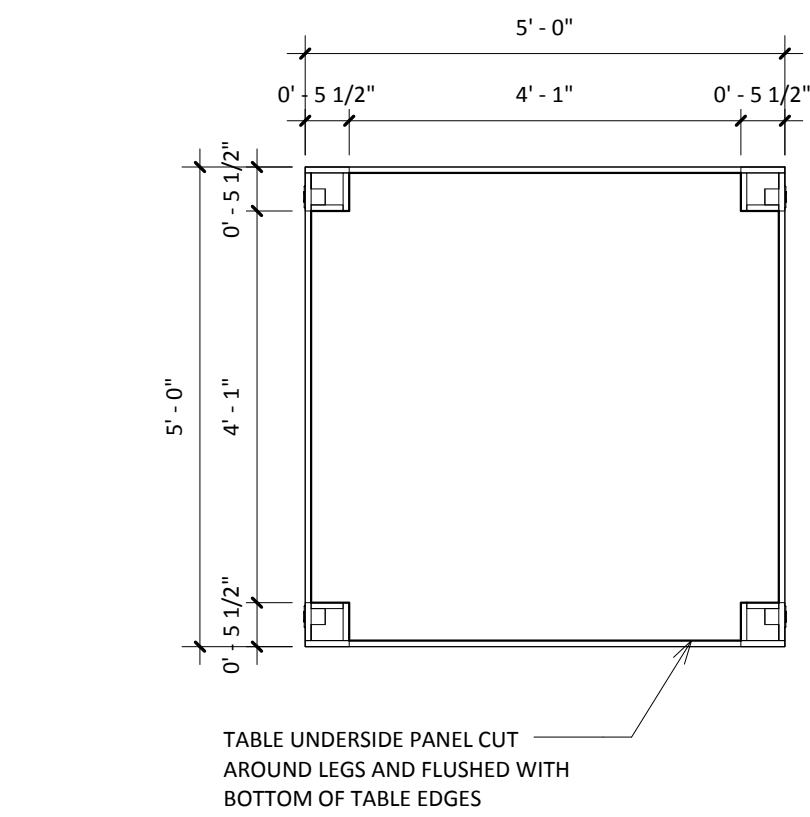
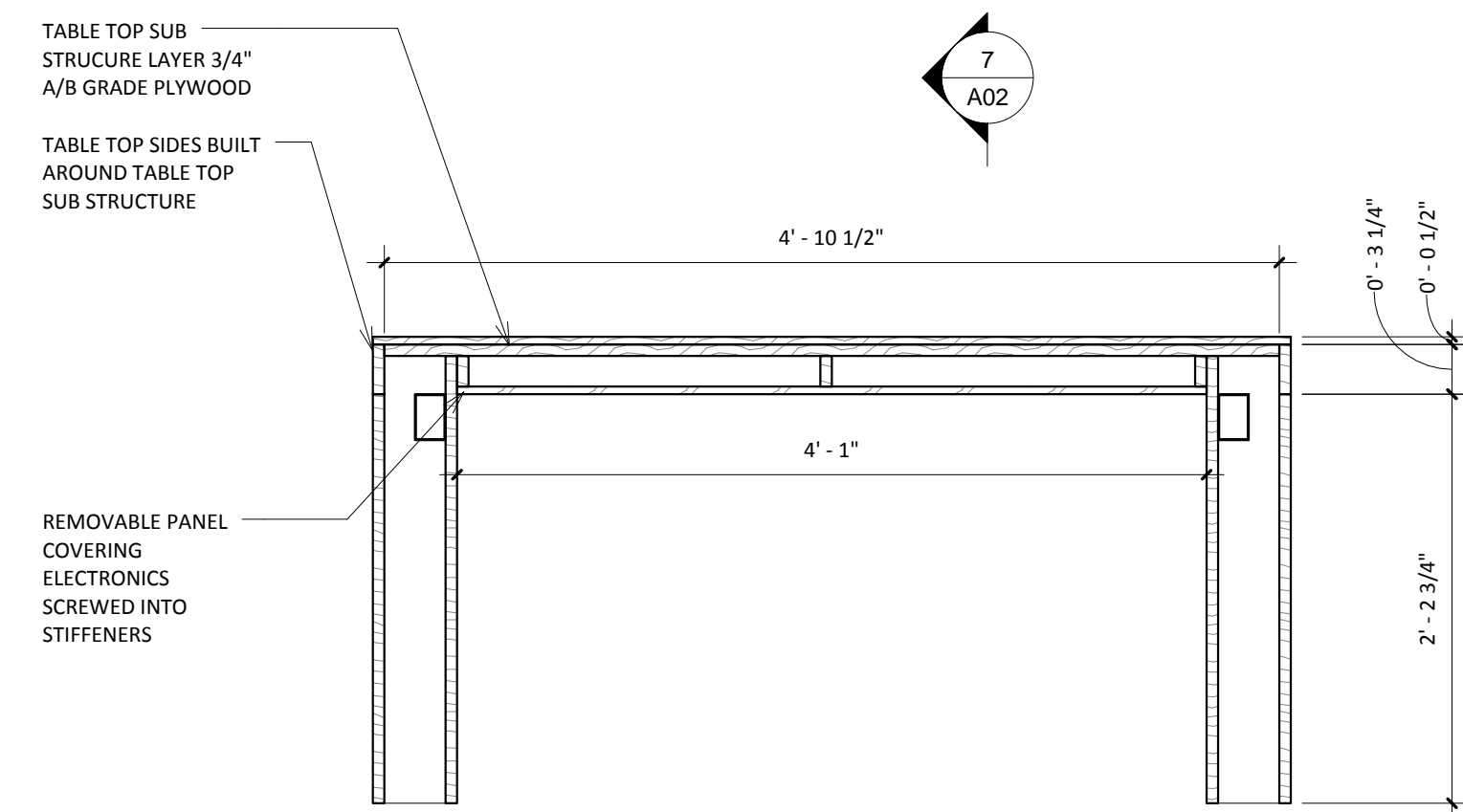

TABLE UNDERSIDE

1/2" = 1'-0"

9



LOGO TABLE SECTION AT LEGS

1" = 1'-0"

8

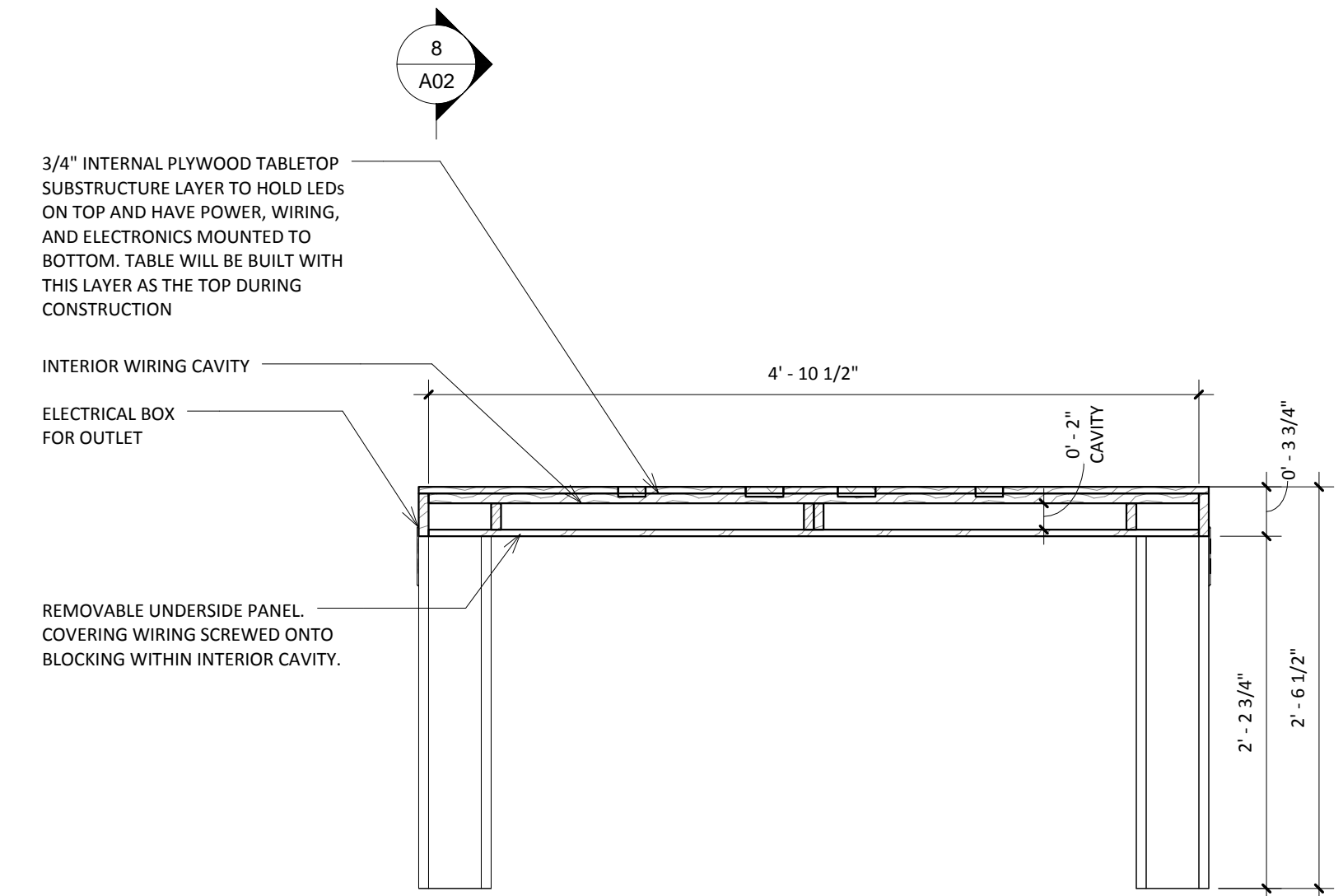

LOGO TABLE SECTION

1" = 1'-0"

7

GENERAL NOTES

1. FINISH PLYWOOD TO BE DETERMINED BY LOCAL AVAILABILITY
2. TABLE TOP IS 1/2" PLYWOOD, ALL OTHER PLYWOOD IS 3/4"
3. TABLE TOP SUB STRUCTURE LAYER TO BE ROUTED WITH TABLE TOP. TABLE TO BE BUILT TO NEAR COMPLETION USING SUB STRUCTURE AS TABLE TOP. ONCE TABLE IS OPERATIONAL AND STRUCTURE IS COMPLETE, TABLE TOP WILL BE INSTALLED.
4. HOLES FOR FASTENERS ON BOTTOM PANEL TO BE DRILLED THROUGH TO ENSURE FLUSH FIT TO STIFFENERS
5. SEE PROJECT DRAWINGS FOR SCHEMATIC WIRING DIAGRAM.
6. SEE WIKI PAGE FOR FURTHER SPECS https://noisebridge.net/wiki/Maker_Faire_2015

MATERIAL ESTIMATES (WOOD):
2 SHEETS 1/2" FINISH PLYWOOD, 1 SHEET 3/4" FINISH PLYWOOD, 4 SHEETS A OR A/B GRADE PLYWOOD FOR STRUCTURE. REMAINDERS TO BE USED ON BOOTH CABINERY.

REVISIONS

Primary Contact:
Jarrod Hicks
hicksu@gmail.com
on Slack as "Jarrod"

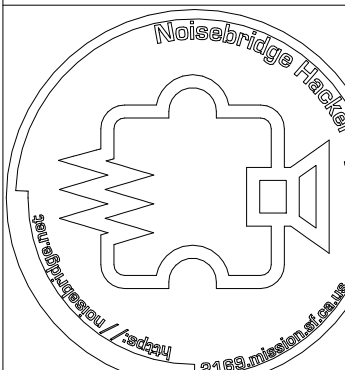

Noisebridge MakerFaire Table

2169 MISSION ST. SAN FRANCISCO CA.

WORKING DRAWING, INTENDED FOR CONSTRUCTION

TABLE DRAWINGS

Date 2/25/2015 22:55:47

Scale As indicated

Drawn JH

File

Sheet

A02

C:\Dropbox\Noisebridge\MakerFaire_2015\Noisebridge_MakerFaire_Booth_ConstructionDrawings_Current